

# Datasheet

## Bluetron™ Module

### BTR501 / BTR502 / BTR503

## Key Features

- A small and cost effective Bluetooth® system
- Bluetooth® specification v2.1 +EDR compliant
- Class 2, up to 10-meter range
- Complete 2.4GHz Bluetooth® System including:
  - Hardware: Radio, Baseband, Crystal and Flash Memory
  - Standard Firmware: HCI or RFCOMM stack
- 64MIPS Kalimba DSP co-processor
- Integrated 1.8V, 1.5V regulators (linear or switching mode)
- Compact size: 14.50 mm x 18.40 mm x 2.20 mm
- Built-in stereo CODEC
- Integrated battery charger
- 4.2V tolerant LED driver
- Support multiple connections
- Optional noise reduction and echo cancellation software library
- Optional text-to-speech software library
- Enhanced audio quality 95dB SNR for DAC
- Surface mount module for embedded applications
- Several firmware options
- Rewritable flash memory (BTR501 – 8Mbit, BTR502 - 16Mbit, BTR503 - 32Mbit) for easy upgrade route
- External antenna design
- External audio input (microphone / line in) circuit
- External audio input (microphone / line in) adjustable bias voltage / current



## Description

**Bluetron™ BTR501/BTR502/BTR503 module** from AvantWave is a complete Bluetooth® solution for fast implementation, cutting your time-to-market. It is a short-range, compact and cost effective radio/baseband module system that can be implemented in any kind of electronic devices, such as hands-free car kit, stereo headset/headphone, home audio system, etc.

In standard configuration the module includes a baseband processor with on board Flash memory, a radio front-end, supporting circuitry, together with some higher-level software protocols and applications such as HSP, HFP, A2DP, AVRCP are resided in the Flash.

The **Bluetron™ BTR501/BTR502/BTR503 module** is a power class 2 Bluetooth® device, and is in compliance with version 2.1 +EDR of the Bluetooth® specification. It is supplied with Bluetooth® protocol stack firmware which runs on the internal microprocessor. **Bluetron™ BTR501/BTR502/BTR503 module** is built on CSR BC05 Multimedia External core with Flash memory for firmware and application software storage.

## Applications

- Stereo Bluetooth Headset/Headphone
- Automotive Car Kit Applications
- PMP
- Home Audio System
- VoIP Headset
- Analog and USB Multimedia Dongle
- Automotive Wireless Gateway



[www.avantwave.com](http://www.avantwave.com)

Tel: (852) 2648 9887 Fax: (852) 2646 3713

[inquiry@avantwave.com](mailto:inquiry@avantwave.com)

AvantWave Limited

## Software

The upper layers of the Bluetooth® stack (above HCI) run on-package. No external microcontroller is required. Bluetron™ BTR501/BTR502/BTR503 is integrated with a 16-bit internal stereo audio CODEC, which drives a small speaker and microphone, and power management circuit.

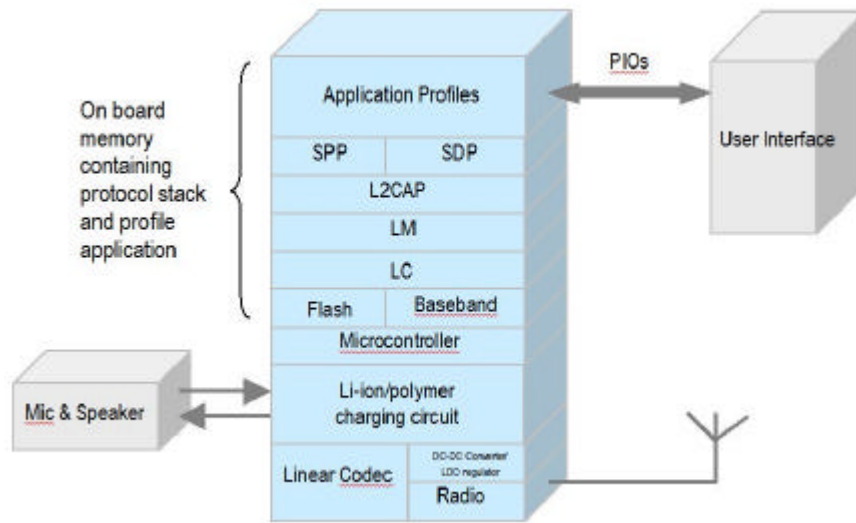

## Mechanical Specification

### Top view

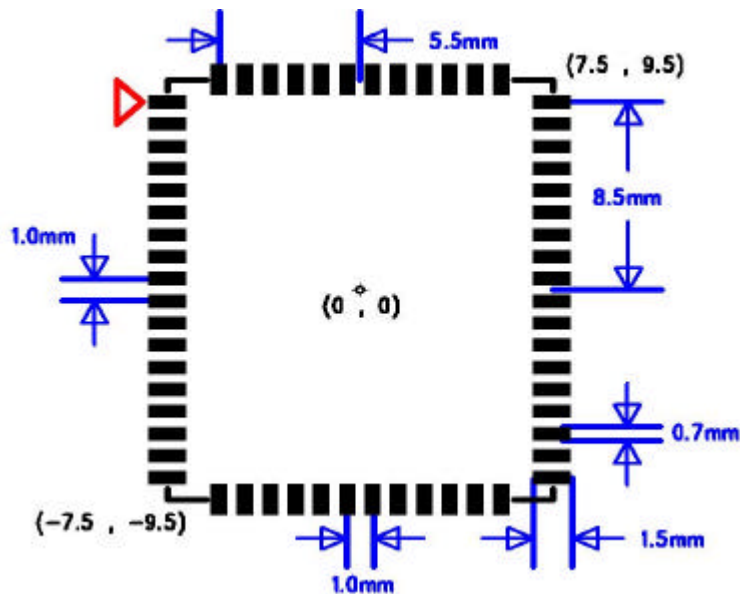

### Side view



www.avantwave.com

Tel: (852) 2648 9887 Fax: (852) 2646 3713

inquiry@avantwave.com

AvantWave Limited

## Pin Assignment

Terminal	Name	Description
1	AIO[0]	Analog Programmable input/output line
2	AIO[1]	Analog Programmable input/output line
3	PIO[3]	Programmable input/output line
4	PIO[4]	Programmable input/output line
5	PIO[5]	Programmable input/output line
6	PIO[6]	Programmable input/output line
7	PIO[7]	Programmable input/output line
8	PIO[8]	Programmable input/output line
9	PIO[9]	Programmable input/output line
10	PIO[10]	Programmable input/output line
11	PIO[11]	Programmable input/output line
12	PIO[12]	Programmable input/output line
13	PIO[13]	Programmable input/output line
14	PIO[14]	Programmable input/output line
15	PIO[15]	Programmable input/output line
16	LED0	LED output, active low
17	LED1	LED output, active low
18	Reset	Reset pin, active low
19	USB_DP	USB data plus
20	USB_DN	USB data minus
21	UART_RTS	UART request to send active low
22	UART_CTS	UART clear to send active low
23	UART_TX	UART data output
24	UART_RX	UART data input
25	GND	Ground
26	PCM_CLK	PCM synchronous data clock
27	PCM_SYNC	PCM synchronous data sync
28	PCM_IN	PCM synchronous data input
29	PCM_OUT	PCM synchronous data output



[www.avantwave.com](http://www.avantwave.com)

Tel: (852) 2648 9887 Fax: (852) 2646 3713

[inquiry@avantwave.com](mailto:inquiry@avantwave.com)

AvantWave Limited

30	GND	Ground
31	SPI_CSB	Chip select for Synchronous Serial Peripheral Interface
32	SPI_MOSI	Serial Peripheral Interface data input
33	SPI_CLK	Serial Peripheral Interface clock
34	SPI_MISO	Serial Peripheral Interface data output
35	VDD_USB	Positive supply for USB ports
36	VREGIN_H	Input to internal high-voltage linear regulator
37	VREGOUT_H	High-voltage linear regulator output
38	+1.8V	1.8V voltage supply/output
39	VDD_CHG	Lithium ion/polymer battery charger input
40	VREGENABLE_H	Enable the high-ion LDO & switching regulator, active high
41	VDD_BAT+	Battery positive terminal
42	VDD_BAT-	Battery negative terminal
43	AGND	Analog ground
44	MIC_B_N	Microphone / Line input negative, right
45	MIC_B_P	Microphone / Line input positive, right
46	MIC_A_N	Microphone / Line input negative, left
47	MIC_A_P	Microphone / Line input positive, left
48	MIC_BIAS	Audio input(microphone / line in) bias
49	SPKR_B_N	Speaker input negative, right
50	SPKR_B_P	Speaker input positive, right
51	SPKR_A_N	Speaker input negative, left
52	SPKR_A_P	Speaker input positive, left
53	AGND	Analog ground
54	GND	Ground
55	ANT	50 Ω antenna port
56	GND	Ground
57	GND	Ground
58	PIO[0]	Programmable input/output line
59	PIO[1]	Programmable input/output line
60	PIO[2]	Programmable input/output line



[www.avantwave.com](http://www.avantwave.com)

Tel: (852) 2648 9887 Fax: (852) 2646 3713

[inquiry@avantwave.com](mailto:inquiry@avantwave.com)

AvantWave Limited

## General Specifications

	Minimum	Typical	Maximum
Supply Voltage: VREG_IN	2.2V	3.3V	4.2V
High Voltage Regulator Output ( $I_{load} = 70$ mA)	1.7V	1.78V	1.85V
Low Voltage Regulator Output ( $I_{load} = 100$ mA)	1.42V	1.5V	1.57V
Operating Temperature range (normal)	-20°C	20°C	85°C
(BTR50x – I)	-40°C	20°C	85°C
Storage Temperature range	-40°C	-	125°C
Frequency Range	2.402 GHz	2.441 GHz	2.480 GHz

\*I – Industrial Grade

## Battery Charger Specifications

		Min	Typ	Max
Supply Voltage: BAT_P		2.5V	3.7V	4.2V
Supply Voltage: V_CHG		4.5V	-	6.5V
Charging Mode Supply Current (BAT_P rises to 4.2V)		-	2mA	-
Battery Fast Charge Current				
(V_CHG – BAT_P > 0.7V)		-	100mA	-
(V_CHG – BAT_P > 0.15V)			50mA	
Standby Mode Supply Current (BAT_P falls from 4.2V)		-	80µA	-
Battery Current		-	-40µA	-
Minimum Load Current		0 mA	-	-
Shutdown Mode (V_CHG too low)	V_CHG rising		3.9V	
V_CHG under-voltage Threshold	V_CHG falling	-	3.7V	-
V_CHG – BAT_P Lockout Threshold	V_CHG rising	-	0.22	-
	V_CHG falling		0.17	
Shutdown Mode Supply Current		-	-	100µA
Shutdown Mode Battery Current		-1µA	-	0µA



[www.avantwave.com](http://www.avantwave.com)

Tel: (852) 2648 9887 Fax: (852) 2646 3713

[inquiry@avantwave.com](mailto:inquiry@avantwave.com)

AvantWave Limited

## RF Specifications (Basic Data Rate)

Voltage Supplies = 1.5V  
 Temperature = 20°C  
 Frequency = 2.441GHz

Receiver	Min	Typ	Max	Bluetooth Specification	Unit
Sensitivity (DH1/3/5) at 0.1% BER	-	-86	-88	=-70	dBm
Maximum received signal at 0.1% BER	-	3	-	=-20	dBm
C/I Co-channel		9	-	=11	dB
C/I Adjacent channel ( $f = f_0 \pm 1\text{MHz}$ )	-	-4	-	<0	dB
C/I Adjacent channel ( $f = f_0 \pm 2\text{MHz}$ )	-	-40	-	=-40	dB
C/I Adjacent channel ( $f = f_0 - 3\text{MHz}$ )	-	-45	-	=-40	dB
C/I Adjacent channel ( $f = f_0 - 5\text{MHz}$ )	-	-45	-	=-40	dB
C/I Image rejection (carrier -3MHz)	-	-20	-	=-9	dB
Transmitter	Min	Typ	Max	Bluetooth Specification	Unit
Average Output Power	-	4	-	+4 to -6	dBm
20dB bandwidth	-	950	-	= 1000	kHz
2 <sup>nd</sup> ACP (+/-2MHz)	-	-35	-	= -20	dBc
3 <sup>rd</sup> ACP (+/-3MHz)	-	-55	-	= -40	dBc



[www.avantwave.com](http://www.avantwave.com)

Tel: (852) 2648 9887 Fax: (852) 2646 3713

[inquiry@avantwave.com](mailto:inquiry@avantwave.com)

AvantWave Limited

## RF Specifications (Enhanced Data Rate)

Voltage Supplies = 1.5V  
 Temperature = 20°C  
 Frequency = 2.441GHz

Receiver	Modulation	Min	Typ	Max	Bluetooth Specification	Unit
Sensitivity (DH1/3/5) at 0.01% BER	p/4 DQPSK 8DPSK	-	-87 -78	-	=-70	dBm
Maximum received signal at 0.1% BER	p/4 DQPSK 8DPSK	-	0	-	-20	dBm
C/I Co-channel at 0.1% BER	p/4 DQPSK 8DPSK		10 19	-	=13 =21	dB
C/I Adjacent channel (f = f <sub>0</sub> +/- 1MHz)	p/4 DQPSK 8DPSK	-	-10 -5	-	=0 =5	dB
C/I Adjacent channel (f = f <sub>0</sub> +/- 2MHz)	p/4 DQPSK 8DPSK	-	=-40	-	=-30 =-25	dB
C/I Adjacent channel (f = f <sub>0</sub> + 3MHz)	p/4 DQPSK 8DPSK	-	-45	-	=-40 =-33	dB
C/I Adjacent channel (f = f <sub>0</sub> - 5MHz)	p/4 DQPSK 8DPSK	-	-45	-	=-40 =-33	dB
C/I Image rejection (carrier -3MHz)	p/4 DQPSK 8DPSK	-	-20 -15	-	=-7 =0	dB
Transmitter		Min	Typ	Max	Bluetooth Specification	Unit
Average Output Power		-	3.5	-	+4 to -6	dBm
Relative Transmit Power		-	-1.2		-4 to +1	dB
In-band spurious emissions	f = f <sub>0</sub> +/- 1MHz	-	-35	-	=-26	dbm
	f = f <sub>0</sub> +/- 2MHz	-	=-34	-	=-20	
	f = f <sub>0</sub> +/- 3MHz	-	=-50	-	=-40	
p/4 DQPSK Modulation Accuracy	Peak DEVM	-	19	-	=35	%
8DPSK Modulation Accuracy	Peak DEVM	-	17	-	=25	%
EDR Differential Phase Encoding		99	No errors	-	=99	%



[www.avantwave.com](http://www.avantwave.com)

Tel: (852) 2648 9887 Fax: (852) 2646 3713

[inquiry@avantwave.com](mailto:inquiry@avantwave.com)

AvantWave Limited

## Power Control & Regulation

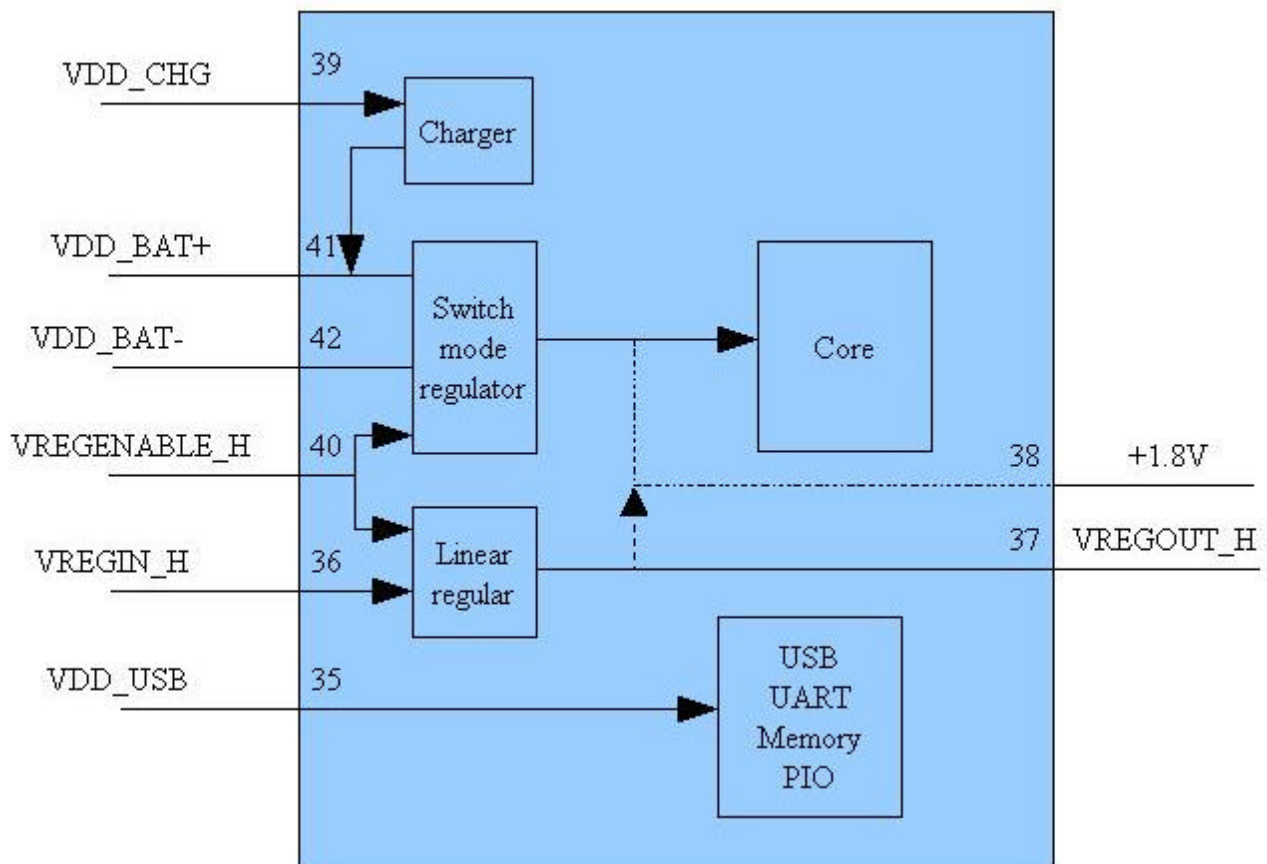

VDD\_CHG (charger input): up to +6.5V dc voltage input

VDD\_BAT+ (battery positive input): up to +4.2V dc voltage input

VDD\_BAT- (battery negative input): battery GND

VREGENABLE\_H (step down DC/DC converter & LDO regulator enable): up to +4.9V dc voltage input

VDD\_USB (positive supply for UART, USB, external flash & PIOs): typically +3V dc voltage input (can change to +1.8V dc depends on different applications)

**Remark:** If VDD\_USB equals to +1.8V, all the UART, USB, external flash & PIOs are set to +1.8V

### LDO Regulator Configuration

VREGIN\_H (LDO regulator positive input): Up to +4.9V dc voltage input

VREGOUT\_H (LDO regulator positive output): Up to +1.8V dv voltage output

\*\*\* Connect VREGOUT\_H to pin 38 (+1.8V)

**Remark:** Default is using step down DC/DC converter, so VREGIN\_H & VREGOUT\_H should be **NO CONNECTION**. If apply the LDO regulator instead of the step down DC/DC converter, then it must remove a coil and capacitor on the BTR501/BTR502/BTR503 module. It means you must not use the LDO regulator configuration except add some modifications in the BTR501/BTR502/BTR503 module. Please refer to Order Information section.



[www.avantwave.com](http://www.avantwave.com)

Tel: (852) 2648 9887 Fax: (852) 2646 3713

[inquiry@avantwave.com](mailto:inquiry@avantwave.com)

AvantWave Limited

## Codec Characteristics

Stereo Codec - Microphone Amplifier	Minimum	Typical	Maximum	Unit
Bandwidth	-	20	-	kHz
Input impedance	-	6	-	kΩ
Resolution	-	16	-	bits
Input full scale at maximum gain	-	4	-	mV rms
Input full scale at minimum gain	-	800	-	mV rms
Distortion at 1kHz	-	-	-74	dB
THD+N at 30mv rms input	-	-66	-	dB
Analog input gain after the analog amplifiers	-3	-	42	dB
Audio input (microphone or line in) bias voltage	0.32	-	1.5	mA
Audio input (microphone or line in) bias current	1.72	-	3.6	V
SNR	-	78	-	dB
Input sample rate	8	-	44.1	kHz
Stereo Codec - Loudspeaker Driver				
Allowed load: resistive	16(8)	-	OC	Ω
Allowed load: capacitive	-	-	500	PF
Output voltage full scale swing	-	750	-	mV rms
Output current drive at full scale swing	-	62	-	mA
THD 16O	-	-	0.1	%
SNR	-	90	95	dB
Resolution	-	16	-	bits
Analog output gain	-24	-	21.5	dB
Output sample rate	8	44.1	48	kHz

## Power Consumption

**Voltage Supplies = 1.8V**  
**Temperature = 20°C**  
**Frequency = 2.441GHz**

Mode	Average	Peak	Unit
SCO connection HV3 (30ms interval sniff mode)(slave)	19.6	-	mA
SCO connection HV3 (30ms interval sniff mode)(Master)	20.1	-	mA
SCO connection HV3 (no sniff mode)(slave)	24.2	-	mA
SCO connection HV1 (Slave)	37.4	-	mA
SCO connection HV1 (Master)	37.6	-	mA
ACL data transfer 115.2kbps UART (Master)	7.9	-	mA
ACL data transfer 115.2kbps UART (slave)	17.1	-	mA
ACL data transfer 921kbps UART (Master or slave)	30	-	mA
ACL connection, sniff mode 40ms interval, 38.4kbps UART	3.2	-	mA
ACL connection, sniff mode 1.28s interval, 38.4kbps UART	0.35	-	mA
Parked Slave, 1.28s beacon interval, 38.kbps UART	0.28	-	mA
Standby Mode (Connected to host, no RF activity)	0.1	-	mA
Reset (RESET high or RESETB low)	57	-	μA



[www.avantwave.com](http://www.avantwave.com)

Tel: (852) 2648 9887 Fax: (852) 2646 3713

[inquiry@avantwave.com](mailto:inquiry@avantwave.com)

AvantWave Limited

## Order Information

---

Flash Memory Size	Voltage Regulator	Order Code
8M bit	Switching mode	BTR501
8M bit	Linear	BTR501L
16M bit	Switching mode	BTR502
16M bit	Linear	BTR502L
32M bit	Switching mode	BTR503
32M bit	Linear	BTR503L

## Solder Profiles

In order to setup your application, it is required to have the soldering profile which is based on various parameters.

Zone	Sensor	Description
Preheat Zone	1-2	This zone raises the temperature at a controlled rate.
Equilibrium Zone	3	This zone brings the board to a uniform temperature and also activates the flux. The duration in this zone will need to be adjusted to optimize the out gassing of the flux.
Reflow Zone	4	The peak temperature should be high enough to achieve good wetting but not so high as to cause component discoloration or damage. Excessive soldering time can lead to intermetallic growth which can result in a brittle joint.
Cooling Zone	5-6	The cooling rate should be fast, to keep the solder grains small which will give longer lasting joint.

### Solder Re-Flow Profile for Devices with Lead-Free Solder Balls

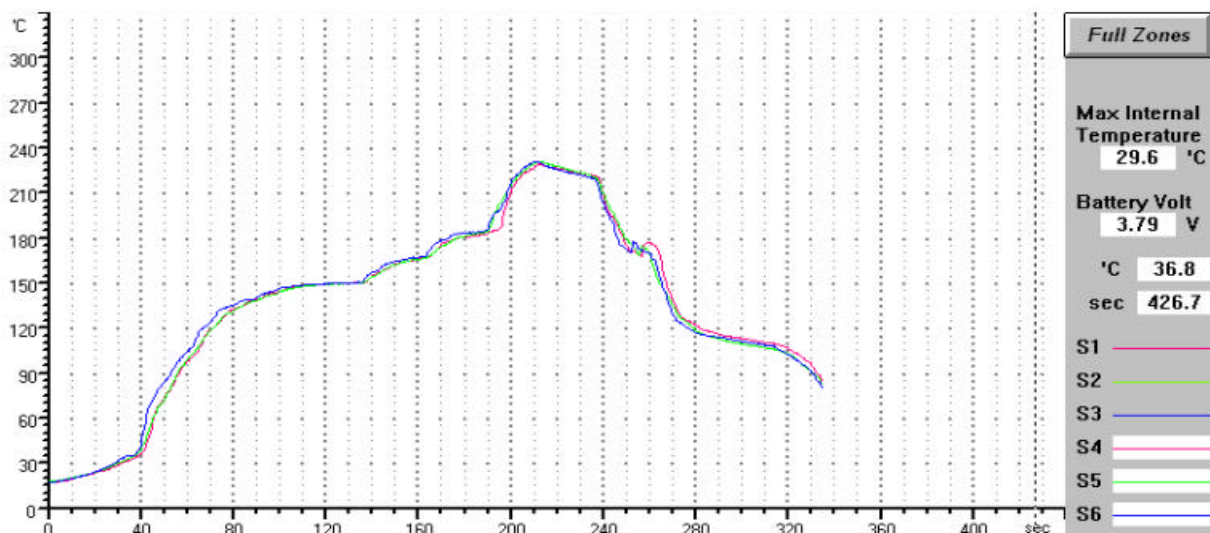

Figure 1.1: Typical Lead-Free Re-flow Solder Profile

#### Temperature Analysis at 200°C

Sensor	Max °C	Max at (s)	Over (s)
S4	229.5	212.5	44
S5	230.6	212.5	49
S6	231.1	211.5	45

#### Remarks

Specifications are subject to change without notice. All other trademarks mentioned are the property of their respective owners. This document shows outlined specification only. Please contact AvantWave upon evaluation and integration.



[www.avantwave.com](http://www.avantwave.com)

Tel: (852) 2648 9887 Fax: (852) 2646 3713

[inquiry@avantwave.com](mailto:inquiry@avantwave.com)

AvantWave Limited